

6" Submersible Motors Standard



Applications

These motors are built for dependable operation in 6" diameter or larger water wells.

Basic Features

- Double flanged NEMA mounting design
- Stainless steel splined shaft
- StatorShield™ Franklin's six feature encapsulation system
- High capacity Kingsbury type water lubricated thrust bearing
- Factory filled with Franklin's non-toxic water soluble fill solution
- Field replaceable lead using Franklin's exclusive Water Bloc™ technology
- Full 3450 rpm 60 Hz design point
- External sand slinger on shaft
- Mechanical face seal at shaft exit
- Copper bar rotor
- All models variable frequency drive (VFD) approved
- Single-phase models must be used with a Franklin Electric control box

Special Options

- Sand Fighter™ Models are equipped with:
 - Franklin's Exclusive Sand Fighter Sealing System for sand or other abrasives well water.
 - Franklin's Exclusive on winding SubTrol™ heat sensor for use with SubMonitor™.
- 316 Stainless Steel construction models come standard with:
 - Franklin's Exclusive Sand Fighter Sealing System for sand or other abrasives well water.
 - Franklin's Exclusive on winding SubTrol heat sensor for use with SubMonitor™.
- SubMonitor is a state-of-the-art electronic motor overload that is sold separately.
 - Mounts in the above ground panel requiring no additional wiring to the motor.
 - User friendly, field proven.
 - Protection monitors for balanced power, overload, underload, overheating, rapid cycling and more.
 - Can be used with or without a SubTrol heat sensor.
 - Supplies superior heat protection when manufactured with the SubTrol heat sensor.

Consult factory for other voltage, hertz and horsepower ratings not listed in this catalog. Specifications are subject to change without notice. Contact Franklin Electric if current materials are required for bid specifications.

6" Submersible Motors Standard

Standard 6-Inch Motor Specifications

Hz	Ph	Hp Range	kW Range	Poles	RPM	Max. Ambient Temp.	Duty Rating
60	1	5 - 15	3.7 - 11	2	3450	86 °F / 30 °C	Continuous at 0.5 ft/sec flow past motor
60	3	5 - 40	3.7 - 30	2	3450	86 °F / 30 °C	Continuous at 0.5 ft/sec flow past motor
60	3	50 - 60	37 - 45	2	3450	122 °F / 50 °C	Continuous at 0.5 ft/sec flow past motor
50	1	5 - 15	3.7 - 11	2	2875	86 °F / 30 °C	Continuous at 0.5 ft/sec flow past motor
50	3	5 - 40	3.7 - 30	2	2875	86 °F / 30 °C	Continuous at 0.5 ft/sec flow past motor
50	3	50 - 60	37 - 45	2	2875	122 °F / 50 °C	Continuous at 0.5 ft/sec flow past motor

6-Inch Construction Materials

Component	Construction Type		
	Standard Water Well	Sand Fighter™	Corrosion Resistant (316 SS)
UL Insulation Class Rating	Class F	Per Standard Water Well	Per Standard Water Well
Motor Ambient Temperature Rating	86 °F / 30 °C (5-40 hp) 122 °F / 50 °C (50-60 hp)	Per Standard Water Well	Per Standard Water Well
Stator Resin Type	FE Standard (5-40 hp) FE Hi-Temp (50-60 hp)	Per Standard Water Well	Per Standard Water Well
Motor Fill Solution (Water Soluble/Non-Toxic)	FES91	Per Standard Water Well	Per Standard Water Well
Top End Bell & Thrust Housing	Epoxy Coated Gray Iron	Per Standard Water Well	316 SS
On Winding SubTrol™ heat sensor	No (5-40 hp) Yes (50-60 hp)	Yes	Yes
Stator Shell	300 SS Series	Per Standard Water Well	316 SS
Stator Ends	Carbon Steel	Per Standard Water Well	316 SS
Shaft Extension	300 SS Series (5-30 hp) 17-4 SS (40-60 hp)	Per Standard Water Well	17-4 SS
Bushing	Bronze	Per Standard Water Well	316 SS
Bushing Retainer	300 SS Series	Per Standard Water Well	316 SS
Shaft Mechanical Seal	Carbon Ceramic Seal (5-40 hp) Sand Fighter™ Seal System (50-60 hp)	Sand Fighter Seal System	Sand Fighter Seal System
Mechanical Seal Rubber Components	Nitrile (5-40 hp) Viton® (50-60 hp)	Per Standard Water Well	Per Standard Water Well
Diaphragm Material	Nitrile (5-40 hp) Viton® (50-60 hp)	Per Standard Water Well	Per Standard Water Well
Diaphragm Plate	300 SS Series	Per Standard Water Well	316 SS
Diaphragm Spring	300 SS Series	Per Standard Water Well	25-6 MO SS
Shaft Slinger	Nitrile (5-40 hp) Viton® (50-60 hp)	Per Standard Water Well	Nitrile
Lead Wire	XLPE	Per Standard Water Well	Per Standard Water Well
Lead Potting	Epoxy	Per Standard Water Well	Per Standard Water Well
Lead Jam Nut	Brass	Per Standard Water Well	316 SS
Thrust Bearing Rating (86 °F / 30 °C)	3500 lbs (5-30 hp) 6000 lbs (40-60 hp)	Per Standard Water Well	Per Standard Water Well
Method Of Connecting System Ground To Motor	Ground Wire In Power Lead Connector	Per Standard Water Well	Per Standard Water Well

Specifications subject to change without notice. Contact Franklin Electric if current material types are required for bid specifications.

Viton® is a registered trademark of DuPont Dow Elastomers.

6" Submersible Motors Standard

6-Inch Dimensions and Weights

Standard Single-Phase Water Well

HP	KW	"L" (inches)	SHIPPING WEIGHT		MOTOR CARTON SIZE (in inches)
			LBS	KG	
5	3.7	25.4	110	50	7.50 x 10.75 x 34.50
7.5	5.5	28	123	56	7.50 x 10.75 x 34.50
10	7.5	30.6	141	64	7.50 x 10.75 x 37.00
15	11	33.1	154	70	7.50 x 10.75 x 42.25

Standard Three-Phase Water Well

HP	KW	"L" (inches)	SHIPPING WEIGHT		MOTOR CARTON SIZE (in inches)
			LBS	KG	
5	3.7	22.9	101	46	7.50 x 10.75 x 34.50
7.5	5.5	24.2	108	49	7.50 x 10.75 x 34.50
10	7.5	25.4	116	53	7.50 x 10.75 x 34.50
15	11	28.0	129	59	7.50 x 10.75 x 34.50
20	15	30.6	145	66	7.50 x 10.75 x 37.00
25	18.5	33.1	156	71	7.50 x 10.75 x 42.25
30	22	35.7	174	79	7.50 x 10.75 x 42.25
40	30	40.8	202	92	7.50 x 10.75 x 47.25
50	37	55.3	300	136	8.75 x 10.50 x 71.75
60	45	61.3	330	150	8.75 x 10.50 x 71.75

6-Lead Y-Δ models available. (Add 5 lbs to shipping weight.)

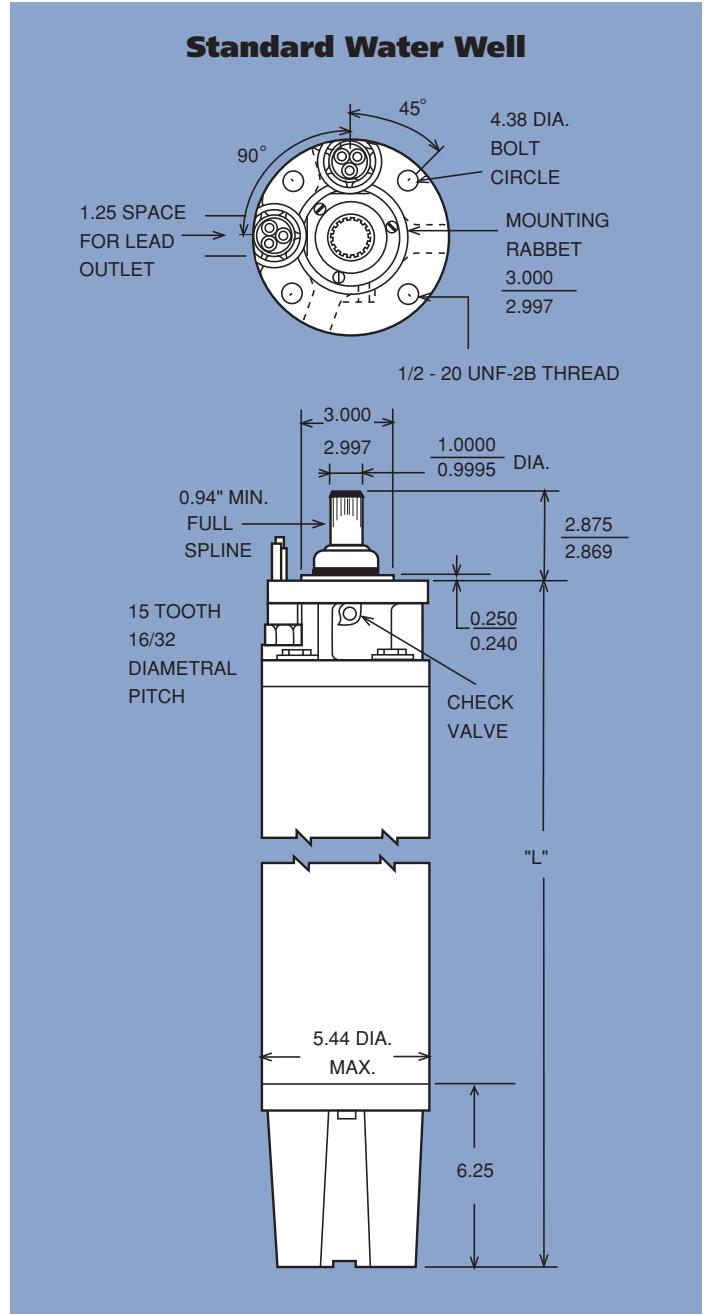

6" Submersible Motors Standard

316 SS Shell Single-Phase 3-Lead

HP	KW	"L" (inches)	SHIPPING WEIGHT		MOTOR CARTON SIZE (in inches)
			LBS	KG	
5	3.7	25.4	110	50	7.50 x 10.75 x 34.50
7.5	5.5	28	123	56	7.50 x 10.75 x 34.50
10	7.5	30.6	141	64	7.50 x 10.75 x 37.00
15	11	33.1	154	70	7.50 x 10.75 x 42.25

316 SS Shell 3-Lead

HP	KW	"L" (inches)	SHIPPING WEIGHT		MOTOR CARTON SIZE (in inches)
			LBS	KG	
5	3.7	22.5	101	46	7.50 x 10.75 x 34.50
7.5	5.5	23.8	108	49	7.50 x 10.75 x 34.50
10	7.5	25.0	116	53	7.50 x 10.75 x 34.50
15	11	27.6	129	59	7.50 x 10.75 x 34.50
20	15	30.2	145	66	7.50 x 10.75 x 37.00
25	18.5	32.7	156	71	7.50 x 10.75 x 42.25
30	22	35.3	174	79	7.50 x 10.75 x 42.25
40	30	40.4	202	92	7.50 x 10.75 x 47.25
50	37	59.2	300	136	8.75 x 10.50 x 71.75
60	45	65.2	330	150	8.75 x 10.50 x 71.75

6-Lead Y-Δ models available. (Add 5 lbs to shipping weight.)

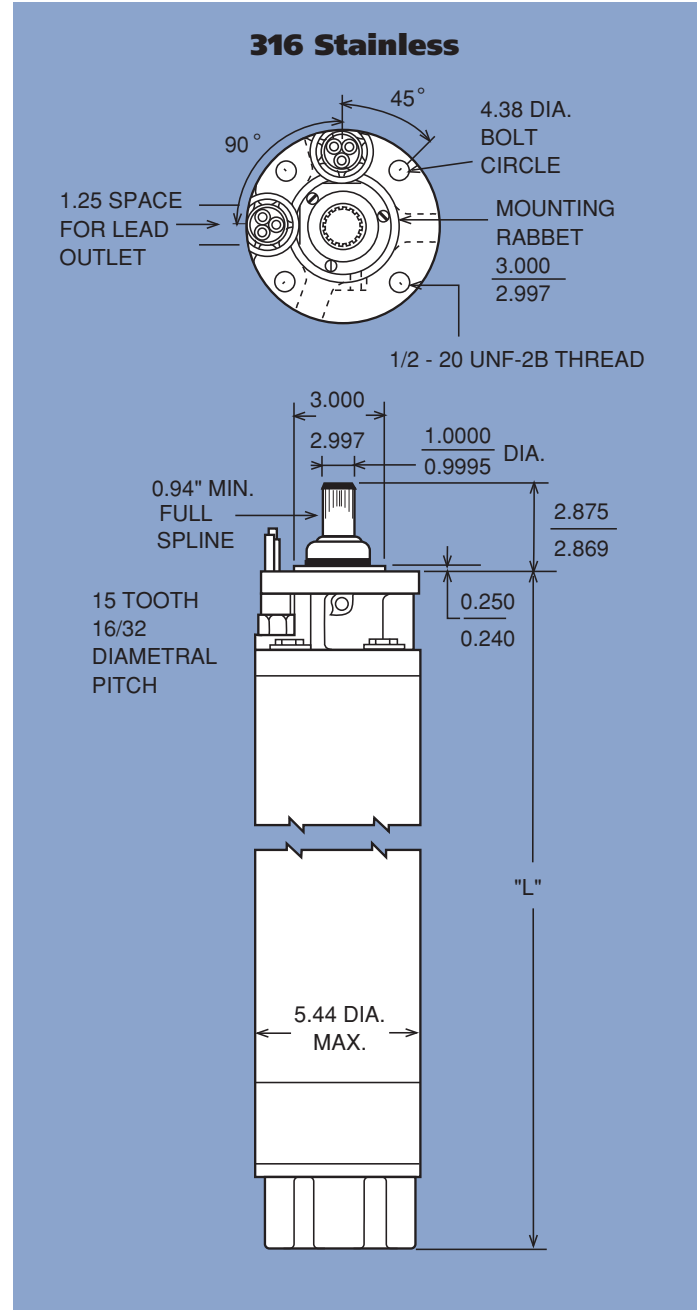

6" Submersible Motors Standard

6-Inch Models

HP (KW)	CONSTRUCTION	DESCRIPTION							MODEL	STOCK STATUS
		PH	VOLTS	HZ	SUBTROL HEAT SENSOR	S.F.	# LEADS	WIRE SIZE (AWG)		
5 hp 3.7 kW	WATER WELL	1P	230	60	Not Available	1.15	3	#10 w/GND	226 110 90	YES
		3P	200-208	60	Not Available	1.15	3	#10 w/GND	236 650 90	YES
		3P	220	50	Not Available	1.00	3	#10 w/GND	236 680 90	
		3P	220	50	Not Available	1.00	6-90°	#10 w/GND	236 670 90	
		3P	230	60	Not Available	1.15	3	#10 w/GND	236 600 90	YES
		3P	230	60	Not Available	1.15	6-90°	#10 w/GND	236 720 90	
		3P	380	60	Not Available	1.15	3	#10 w/GND	236 660 90	
		3P	380	60	Not Available	1.15	6-90°	#10 w/GND	236 780 90	
		3P	415	50	Not Available	1.00	3	#10 w/GND	236 690 90	
		3P	460/380-415	60/50	Not Available	1.15/1.00	3	#10 w/GND	236 610 90	YES
		3P	460/380-415	60/50	Not Available	1.15/1.00	6-90°	#10 w/GND	236 710 90	
		3P	575	60	Not Available	1.15	3	#10 w/GND	236 620 90	
		SAND FIGHTER	1P	230	60	Not Available	1.15	3	#10 w/GND	226 110 80
	3P		200-208	60	YES	1.15	3	#10 w/GND	236 650 81	YES
	3P		220	50	YES	1.00	3	#10 w/GND	236 680 81	
	3P		220	50	YES	1.00	6-90°	#10 w/GND	236 670 81	
	3P		230	60	YES	1.15	3	#10 w/GND	236 600 81	YES
	3P		230	60	YES	1.15	6-90°	#10 w/GND	236 720 81	
	3P		380	60	YES	1.15	3	#10 w/GND	236 660 81	
	3P		380	60	YES	1.15	6-90°	#10 w/GND	236 780 81	
	3P		415	50	YES	1.00	3	#10 w/GND	236 690 81	
	3P		460/380-415	60/50	YES	1.15/1.00	3	#10 w/GND	236 610 81	YES
	3P		460/380-415	60/50	YES	1.15/1.00	6-90°	#10 w/GND	236 710 81	
	3P		575	60	YES	1.15	3	#10 w/GND	236 620 81	YES
	316 SS		1P	230	60	Not Available	1.15	3	#10 w/GND	226 110 39
		3P	200-208	60	YES	1.15	3	#10 w/GND	236 650 40	
		3P	220	50	YES	1.00	3	#10 w/GND	236 680 40	
		3P	220	50	YES	1.00	6-90°	#10 w/GND	236 670 40	
		3P	230	60	YES	1.15	3	#10 w/GND	236 600 40	YES
		3P	230	60	YES	1.15	6-90°	#10 w/GND	236 720 40	
		3P	380	60	YES	1.15	3	#10 w/GND	236 660 40	
		3P	380	60	YES	1.15	6-90°	#10 w/GND	236 780 40	
		3P	415	50	YES	1.15	3	#10 w/GND	236 690 40	
		3P	460/380-415	60/50	YES	1.15/1.00	3	#10 w/GND	236 610 40	YES
		3P	460/380-415	60/50	YES	1.15/1.00	6-90°	#10 w/GND	236 710 40	
		3P	575	60	YES	1.15	3	#10 w/GND	236 620 40	

6" Submersible Motors Standard

6-Inch Models

HP (KW)	CONSTRUCTION	DESCRIPTION							MODEL	STOCK STATUS
		PH	VOLTS	HZ	SUBTROL HEAT SENSOR	S.F.	# LEADS	WIRE SIZE (AWG)		
7.5 hp 5.5 kW	WATER WELL	1P	230	60	Not Available	1.15	3	#10 w/GND	226 111 90	YES
		3P	200-208	60	Not Available	1.15	3	#10 w/GND	236 651 90	YES
		3P	220	50	Not Available	1.00	3	#10 w/GND	236 681 90	
		3P	220	50	Not Available	1.00	6-90°	#10 w/GND	236 671 90	
		3P	230	60	Not Available	1.15	3	#10 w/GND	236 601 90	YES
		3P	230	60	Not Available	1.15	6-90°	#10 w/GND	236 721 90	
		3P	380	60	Not Available	1.15	3	#10 w/GND	236 661 90	YES
		3P	380	60	Not Available	1.15	6-90°	#10 w/GND	236 781 90	
		3P	415	50	Not Available	1.00	3	#10 w/GND	236 691 90	
		3P	460/380-415	60/50	Not Available	1.15/1.00	3	#10 w/GND	236 611 90	YES
		3P	460/380-415	60/50	Not Available	1.15/1.00	6-90°	#10 w/GND	236 711 90	YES
		3P	575	60	Not Available	1.15	3	#10 w/GND	236 621 90	
	SAND FIGHTER	1P	230	60	Not Available	1.15	3	#10 w/GND	226 111 80	YES
		3P	200-208	60	YES	1.15	3	#10 w/GND	236 651 81	YES
		3P	220	50	YES	1.00	3	#10 w/GND	236 681 81	
		3P	220	50	YES	1.00	6-90°	#10 w/GND	236 671 81	
		3P	230	60	YES	1.15	3	#10 w/GND	236 601 81	YES
		3P	230	60	YES	1.15	6-90°	#10 w/GND	236 721 81	
		3P	380	60	YES	1.15	3	#10 w/GND	236 661 81	
		3P	380	60	YES	1.15	6-90°	#10 w/GND	236 781 81	
		3P	415	50	YES	1.00	3	#10 w/GND	236 691 81	
		3P	460/380-415	60/50	YES	1.15/1.00	3	#10 w/GND	236 611 81	YES
		3P	460/380-415	60/50	YES	1.15/1.00	6-90°	#10 w/GND	236 711 81	
		3P	575	60	YES	1.15	3	#10 w/GND	236 621 81	YES
	316 SS	1P	230	60	Not Available	1.15	3	#10 w/GND	226 111 39	
		3P	200-208	60	YES	1.15	3	#10 w/GND	236 651 40	
		3P	220	50	YES	1.00	3	#10 w/GND	236 681 40	
		3P	220	50	YES	1.00	6-90°	#10 w/GND	236 671 40	
		3P	230	60	YES	1.15	3	#10 w/GND	236 601 40	YES
		3P	230	60	YES	1.15	6-90°	#10 w/GND	236 721 40	
		3P	380	60	YES	1.15	3	#10 w/GND	236 661 40	
		3P	380	60	YES	1.15	6-90°	#10 w/GND	236 781 40	
		3P	415	50	YES	1.00	3	#10 w/GND	236 691 81	
		3P	460/380-415	60/50	YES	1.15/1.00	3	#10 w/GND	236 611 40	YES
		3P	460/380-415	60/50	YES	1.15/1.00	6-90°	#10 w/GND	236 711 40	
		3P	575	60	YES	1.15	3	#10 w/GND	236 621 40	

6" Submersible Motors Standard

6-Inch Models

HP (KW)	CONSTRUCTION	DESCRIPTION							MODEL	STOCK STATUS
		PH	VOLTS	HZ	SUBTROL HEAT SENSOR	S.F.	# LEADS	WIRE SIZE (AWG)		
10 hp 7.5 kW	WATER WELL	1P	230	60	Not Available	1.15	3	#10 w/GND	226 112 90	YES
		3P	200-208	60	Not Available	1.15	3	#10 w/GND	236 652 90	YES
		3P	220	50	Not Available	1.00	3	#10 w/GND	236 682 90	
		3P	220	50	Not Available	1.00	6-90°	#10 w/GND	236 672 90	
		3P	230	60	Not Available	1.15	3	#10 w/GND	236 602 90	YES
		3P	230	60	Not Available	1.15	6-90°	#10 w/GND	236 722 90	
		3P	380	60	Not Available	1.15	3	#10 w/GND	236 662 90	YES
		3P	380	60	Not Available	1.15	6-90°	#10 w/GND	236 782 90	
		3P	415	50	Not Available	1.00	3	#10 w/GND	236 692 90	
		3P	460/380-415	60/50	Not Available	1.15/1.00	3	#10 w/GND	236 612 90	YES
		3P	460/380-415	60/50	Not Available	1.15/1.00	6-90°	#10 w/GND	236 712 90	YES
		3P	575	60	Not Available	1.15	3	#10 w/GND	236 622 90	
	SAND FIGHTER	1P	230	60	Not Available	1.15	3	#10 w/GND	226 112 80	YES
		3P	200-208	60	YES	1.15	3	#10 w/GND	236 652 81	YES
		3P	220	50	YES	1.00	3	#10 w/GND	236 682 81	
		3P	220	50	YES	1.00	6-90°	#10 w/GND	236 672 81	
		3P	230	60	YES	1.15	3	#10 w/GND	236 602 81	YES
		3P	230	60	YES	1.15	6-90°	#10 w/GND	236 722 81	
		3P	380	60	YES	1.15	3	#10 w/GND	236 662 81	
		3P	380	60	YES	1.15	6-90°	#10 w/GND	236 782 81	
		3P	415	50	YES	1.00	3	#10 w/GND	236 692 81	
		3P	460/380-415	60/50	YES	1.15/1.00	3	#10 w/GND	236 612 81	YES
		3P	460/380-415	60/50	YES	1.15/1.00	6-90°	#10 w/GND	236 712 81	
		3P	575	60	YES	1.15	3	#10 w/GND	236 622 81	YES
	316 SS	1P	230	60	Not Available	1.15	3	#10 w/GND	226 112 39	
		3P	200-208	60	YES	1.15	3	#10 w/GND	236 652 40	
		3P	220	50	YES	1.00	3	#10 w/GND	236 682 40	
		3P	220	50	YES	1.00	6-90°	#10 w/GND	236 672 40	
		3P	230	60	YES	1.15	3	#10 w/GND	236 602 40	YES
		3P	230	60	YES	1.15	6-90°	#10 w/GND	236 722 40	
		3P	380	60	YES	1.15	3	#10 w/GND	236 662 40	
		3P	380	60	YES	1.15	6-90°	#10 w/GND	236 782 40	
		3P	415	50	YES	1.00	3	#10 w/GND	236 692 40	
3P		460/380-415	60/50	YES	1.15/1.00	3	#10 w/GND	236 612 40	YES	
3P		460/380-415	60/50	YES	1.15/1.00	6-90°	#10 w/GND	236 712 40		
3P		575	60	YES	1.15	3	#10 w/GND	236 622 40		

6" Submersible Motors Standard

6-Inch Models

HP (KW)	CONSTRUCTION	DESCRIPTION							MODEL	STOCK STATUS
		PH	VOLTS	HZ	SUBTROL HEAT SENSOR	S.F.	# LEADS	WIRE SIZE (AWG)		
15 hp 11 kW	WATER WELL	1P	230	60	Not Available	1.15	3	#10 w/GND	226 113 90	YES
		3P	200-208	60	Not Available	1.15	3	#10 w/GND	236 653 90	YES
		3P	220	50	Not Available	1.00	3	#10 w/GND	236 683 90	
		3P	220	50	Not Available	1.00	6-90°	#10 w/GND	236 673 90	
		3P	230	60	Not Available	1.15	3	#10 w/GND	236 603 90	YES
		3P	230	60	Not Available	1.15	6-90°	#10 w/GND	236 723 90	YES
		3P	380	60	Not Available	1.15	3	#10 w/GND	236 663 90	YES
		3P	380	60	Not Available	1.15	6-90°	#10 w/GND	236 783 90	
		3P	415	50	Not Available	1.00	3	#10 w/GND	236 693 90	
		3P	460/380-415	60/50	Not Available	1.15/1.00	3	#10 w/GND	236 613 90	YES
		3P	460/380-415	60/50	Not Available	1.15/1.00	6-90°	#10 w/GND	236 713 90	YES
		3P	575	60	Not Available	1.15	3	#10 w/GND	236 623 90	
	SAND FIGHTER	1P	230	60	Not Available	1.15	3	#10 w/GND	226 113 80	YES
		3P	200-208	60	YES	1.15	3	#10 w/GND	236 653 81	YES
		3P	220	50	YES	1.00	3	#10 w/GND	236 683 81	
		3P	220	50	YES	1.00	6-90°	#10 w/GND	236 673 81	
		3P	230	60	YES	1.15	3	#10 w/GND	236 603 81	YES
		3P	230	60	YES	1.15	6-90°	#10 w/GND	236 723 81	
		3P	380	60	YES	1.15	3	#10 w/GND	236 663 81	
		3P	380	60	YES	1.15	6-90°	#10 w/GND	236 783 81	
		3P	415	50	YES	1.00	3	#10 w/GND	236 693 81	
		3P	460/380-415	60/50	YES	1.15/1.00	3	#10 w/GND	236 613 81	YES
		3P	460/380-415	60/50	YES	1.15/1.00	6-90°	#10 w/GND	236 713 81	
		3P	575	60	YES	1.15	3	#10 w/GND	236 623 81	YES
	316 SS	1P	230	60	Not Available	1.15	3	#10 w/GND	226 113 39	
		3P	200-208	60	YES	1.15	3	#10 w/GND	236 653 40	
		3P	220	50	YES	1.00	3	#10 w/GND	236 683 40	
		3P	220	50	YES	1.00	6-90°	#10 w/GND	236 673 40	
		3P	230	60	YES	1.15	3	#10 w/GND	236 603 40	YES
		3P	230	60	YES	1.15	6-90°	#10 w/GND	236 723 40	
		3P	380	60	YES	1.15	3	#10 w/GND	236 663 40	
		3P	380	60	YES	1.15	6-90°	#10 w/GND	236 783 40	
		3P	415	50	YES	1.00	3	#10 w/GND	236 693 40	
		3P	460/380-415	60/50	YES	1.15/1.00	3	#10 w/GND	236 613 40	YES
		3P	460/380-415	60/50	YES	1.15/1.00	6-90°	#10 w/GND	236 713 40	
		3P	575	60	YES	1.15	3	#10 w/GND	236 623 40	

6" Submersible Motors Standard

6-Inch Models

HP (KW)	CONSTRUCTION	DESCRIPTION							MODEL	STOCK STATUS
		PH	VOLTS	HZ	SUBTROL HEAT SENSOR	S.F.	# LEADS	WIRE SIZE (AWG)		
20 hp 15 kW	WATER WELL	3P	200-208	60	Not Available	1.15	3	#8 w/GND	236 654 90	YES
		3P	220	50	Not Available	1.00	3	#8 w/GND	236 684 90	
		3P	220	60	Not Available	1.15	6-90°	#10 w/GND	236 674 90	
		3P	230	60	Not Available	1.15	3	#8 w/GND	236 604 90	YES
		3P	230	60	Not Available	1.15	6-90°	#10 w/GND	236 724 90	
		3P	380	60	Not Available	1.15	3	#10 w/GND	236 664 90	YES
		3P	380	60	Not Available	1.15	6-90°	#10 w/GND	236 784 90	
		3P	415	50	Not Available	1.00	3	#10 w/GND	236 694 90	
		3P	460/380-415	60/50	Not Available	1.15/1.00	3	#10 w/GND	236 614 90	YES
		3P	460/380-415	60/50	Not Available	1.15/1.00	6-90°	#10 w/GND	236 714 90	YES
		3P	575	60	Not Available	1.15	3	#10 w/GND	236 624 90	
	SAND FIGHTER	3P	200-208	60	YES	1.15	3	#8 w/GND	236 654 81	YES
		3P	220	50	YES	1.00	3	#8 w/GND	236 684 81	
		3P	220	50	YES	1.00	6-90°	#10 w/GND	236 674 81	
		3P	230	60	YES	1.15	3	#8 w/GND	236 604 81	YES
		3P	230	60	YES	1.15	6-90°	#10 w/GND	236 724 81	YES
		3P	380	60	YES	1.15	3	#10 w/GND	236 664 81	
		3P	380	60	YES	1.15	6-90°	#10 w/GND	236 784 81	
		3P	415	50	YES	1.00	3	#10 w/GND	236 694 81	
		3P	460/380-415	60/50	YES	1.15/1.00	3	#10 w/GND	236 614 81	YES
		3P	460/380-415	60/50	YES	1.15/1.00	6-90°	#10 w/GND	236 714 81	
		3P	575	60	YES	1.15	3	#10 w/GND	236 624 81	YES
	316 SS	3P	200-208	60	YES	1.15	3	#8 w/GND	236 654 40	
		3P	220	50	YES	1.00	3	#8 w/GND	236 684 40	
		3P	220	50	YES	1.00	6-90°	#10 w/GND	236 674 40	
		3P	230	60	YES	1.15	3	#8 w/GND	236 604 40	YES
		3P	230	60	YES	1.15	6-90°	#10 w/GND	236 724 40	
		3P	380	60	YES	1.15	3	#10 w/GND	236 664 40	
		3P	380	60	YES	1.15	6-90°	#10 w/GND	236 784 40	
		3P	415	50	YES	1.00	3	#10 w/GND	236 694 40	
		3P	460/380-415	60/50	YES	1.15/1.00	3	#10 w/GND	236 614 40	YES
		3P	460/380-415	60/50	YES	1.15/1.00	6-90°	#10 w/GND	236 714 40	
		3P	575	60	YES	1.15	3	#10 w/GND	236 624 40	

6" Submersible Motors Standard

6-Inch Models

HP (KW)	CONSTRUCTION	DESCRIPTION							MODEL	STOCK STATUS
		PH	VOLTS	HZ	SUBTROL HEAT SENSOR	S.F.	# LEADS	WIRE SIZE (AWG)		
25 hp 18.5 kW	WATER WELL	3P	200-208	60	Not Available	1.15	3	#8 w/GND	236 655 90	YES
		3P	220	50	Not Available	1.00	3	#8 w/GND	236 685 90	
		3P	220	50	Not Available	1.00	6-90°	#10 w/GND	236 675 90	
		3P	230	60	Not Available	1.15	3	#8 w/GND	236 605 90	YES
		3P	230	60	Not Available	1.15	6-90°	#10 w/GND	236 725 90	
		3P	380	60	Not Available	1.15	3	#10 w/GND	236 665 90	YES
		3P	380	60	Not Available	1.15	6-90°	#10 w/GND	236 785 90	
		3P	415	50	Not Available	1.00	3	#10 w/GND	236 695 90	
		3P	460/380-415	60/50	Not Available	1.15/1.00	3	#10 w/GND	236 615 90	YES
		3P	460/380-415	60/50	Not Available	1.15/1.00	6-90°	#10 w/GND	236 715 90	YES
		3P	575	60	Not Available	1.15	3	#10 w/GND	236 625 90	
	SAND FIGHTER	3P	200-208	60	YES	1.15	3	#8 w/GND	236 655 81	YES
		3P	220	50	YES	1.00	3	#8 w/GND	236 685 81	
		3P	220	50	YES	1.00	6-90°	#10 w/GND	236 675 81	
		3P	230	60	YES	1.15	3	#8 w/GND	236 605 81	YES
		3P	230	60	YES	1.15	6-90°	#10 w/GND	236 725 81	YES
		3P	380	60	YES	1.15	3	#10 w/GND	236 665 81	
		3P	380	60	YES	1.15	6-90°	#10 w/GND	236 785 81	
		3P	415	50	YES	1.00	3	#10 w/GND	236 695 81	
		3P	460/380-415	60/50	YES	1.15/1.00	3	#10 w/GND	236 615 81	YES
		3P	460/380-415	60/50	YES	1.15/1.00	6-90°	#10 w/GND	236 715 81	
		3P	575	60	YES	1.15	3	#10 w/GND	236 625 81	YES
	316 SS	3P	200-208	60	YES	1.15	3	#8 w/GND	236 655 40	
		3P	220	50	YES	1.00	3	#8 w/GND	236 685 40	
		3P	220	50	YES	1.00	6-90°	#10 w/GND	236 675 40	
		3P	230	60	YES	1.15	3	#8 w/GND	236 605 40	
		3P	230	60	YES	1.15	6-90°	#10 w/GND	236 725 40	
		3P	380	60	YES	1.15	3	#10 w/GND	236 665 40	
		3P	380	60	YES	1.15	6-90°	#10 w/GND	236 785 40	
		3P	415	50	YES	1.00	3	#10 w/GND	236 695 40	
		3P	460/380-415	60/50	YES	1.15/1.00	3	#10 w/GND	236 615 40	YES
		3P	460/380-415	60/50	YES	1.15/1.00	6-90°	#10 w/GND	236 715 40	
		3P	575	60	YES	1.15	3	#10 w/GND	236 625 40	

6" Submersible Motors Standard

6-Inch Models

HP (KW)	CONSTRUCTION	DESCRIPTION							MODEL	STOCK STATUS
		PH	VOLTS	HZ	SUBTROL HEAT SENSOR	S.F.	# LEADS	WIRE SIZE (AWG)		
30 hp 22 kW	WATER WELL	3P	200-208	60	Not Available	1.15	3	#8 w/GND	236 656 90	YES
		3P	220	50	Not Available	1.00	3	#8 w/GND	236 686 90	
		3P	220	50	Not Available	1.00	6-90°	#10 w/GND	236 676 90	
		3P	230	60	Not Available	1.15	3	#8 w/GND	236 606 90	YES
		3P	230	60	Not Available	1.15	6-90°	#10 w/GND	236 726 90	
		3P	380	60	Not Available	1.15	3	#10 w/GND	236 666 90	YES
		3P	380	60	Not Available	1.15	6-90°	#10 w/GND	236 786 90	
		3P	415	50	Not Available	1.00	3	#10 w/GND	236 696 90	
		3P	460/380-415	60/50	Not Available	1.15/1.00	3	#10 w/GND	236 616 90	YES
		3P	460/380-415	60/50	Not Available	1.15/1.00	6-90°	#10 w/GND	236 716 90	YES
	3P	575	60	Not Available	1.15	3	#10 w/GND	236 626 90		
	SAND FIGHTER	3P	200-208	60	YES	1.15	3	#8 w/GND	236 656 81	YES
		3P	220	50	YES	1.00	3	#8 w/GND	236 686 81	
		3P	220	50	YES	1.00	6-90°	#10 w/GND	236 676 81	
		3P	230	60	YES	1.15	3	#8 w/GND	236 606 81	YES
		3P	230	60	YES	1.15	6-90°	#10 w/GND	236 726 81	YES
		3P	380	60	YES	1.15	3	#10 w/GND	236 666 81	
		3P	380	60	YES	1.15	6-90°	#10 w/GND	236 786 81	
		3P	415	50	YES	1.00	3	#10 w/GND	236 696 81	
		3P	460/380-415	60/50	YES	1.15/1.00	3	#10 w/GND	236 616 81	YES
		3P	460/380-415	60/50	YES	1.15/1.00	6-90°	#10 w/GND	236 716 81	
	3P	575	60	YES	1.15	3	#10 w/GND	236 626 81	YES	
	316 SS	3P	200-208	60	YES	1.15	3	#8 w/GND	236 656 40	
		3P	220	50	YES	1.00	3	#8 w/GND	236 686 40	
		3P	220	50	YES	1.00	6-90°	#10 w/GND	236 676 40	
		3P	230	60	YES	1.15	3	#8 w/GND	236 606 40	
		3P	230	60	YES	1.15	6-90°	#10 w/GND	236 726 40	
		3P	380	60	YES	1.15	3	#10 w/GND	236 666 40	
		3P	380	60	YES	1.15	6-90°	#10 w/GND	236 786 40	
		3P	415	50	YES	1.00	3	#10 w/GND	236 696 40	
3P		460/380-415	60/50	YES	1.15/1.00	3	#10 w/GND	236 616 40	YES	
3P		460/380-415	60/50	YES	1.15/1.00	6-90°	#10 w/GND	236 716 40		
3P	575	60	YES	1.15	3	#10 w/GND	236 626 40			

6" Submersible Motors Standard

6-Inch Models

HP (KW)	CONSTRUCTION	DESCRIPTION							MODEL	STOCK STATUS
		PH	VOLTS	HZ	SUBTROL HEAT SENSOR	S.F.	# LEADS	WIRE SIZE (AWG)		
40 hp 30 kW	WATER WELL	3P	380	60	Not Available	1.15	3	#8 w/GND	236 667 90	
		3P	380	60	Not Available	1.15	6-90°	#10 w/GND	236 787 90	
		3P	415	50	Not Available	1.00	3	#8 w/GND	236 697 90	
		3P	460/380-415	60/50	Not Available	1.15/1.00	3	#8 w/GND	236 617 90	YES
		3P	460/380-415	60/50	Not Available	1.15/1.00	6-90°	#10 w/GND	236 717 90	
		3P	575	60	Not Available	1.15	3	#8 w/GND	236 627 90	
	SAND FIGHTER	3P	380	60	YES	1.15	3	#8 w/GND	236 667 81	YES
		3P	380	60	YES	1.15	6-90°	#10 w/GND	236 787 81	
		3P	415	50	YES	1.00	3	#8 w/GND	236 697 81	
		3P	460/380-415	60/50	YES	1.15/1.00	3	#8 w/GND	236 617 81	YES
		3P	460/380-415	60/50	YES	1.15/1.00	6-90°	#10 w/GND	236 717 81	YES
		3P	575	60	YES	1.15	3	#8 w/GND	236 627 81	YES
	316 SS	3P	380	60	YES	1.15	3	#8 w/GND	236 667 40	
		3P	380	60	YES	1.15	6-90°	#10 w/GND	236 787 40	
		3P	415	50	YES	1.00	3	#8 w/GND	236 697 40	
		3P	460/380-415	60/50	YES	1.15/1.00	3	#8 w/GND	236 617 40	YES
		3P	460/380-415	60/50	YES	1.15/1.00	6-90°	#10 w/GND	236 717 40	
		3P	575	60	YES	1.15	3	#8 w/GND	236 627 40	
50 hp 30 kW	WATER WELL WITH SAND FIGHTER SEAL	3P	380	60	YES	1.15	3	#8 w/GND	276 668 60	YES
		3P	380	60	YES	1.15	6-90°	#8 w/GND	276 788 60	
		3P	415	50	YES	1.00	3	#8 w/GND	276 698 60	
		3P	460/380-415	60/50	YES	1.15/1.00	3	#8 w/GND	276 618 60	YES
		3P	460/380-415	60/50	YES	1.15/1.00	6-90°	#8 w/GND	276 718 60	YES
		3P	575	60	YES	1.15	3	#8 w/GND	276 628 60	YES
	316 SS	3P	380	60	YES	1.15	3	#8 w/GND	276 668 40	
		3P	380	60	YES	1.15	6-90°	#8 w/GND	276 788 40	
		3P	415	50	YES	1.00	3	#8 w/GND	276 698 40	
		3P	460/380-415	60/50	YES	1.15/1.00	3	#8 w/GND	276 618 40	YES
		3P	460/380-415	60/50	YES	1.15/1.00	6-90°	#8 w/GND	276 718 40	
		3P	575	60	YES	1.15	3	#8 w/GND	276 628 40	
60 hp 45 kW	WATER WELL WITH SAND FIGHTER SEAL	3P	380	60	YES	1.15	3	#8 w/GND	276 669 60	YES
		3P	380	60	YES	1.15	6-90°	#8 w/GND	276 789 60	
		3P	415	50	YES	1.00	3	#8 w/GND	276 699 60	
		3P	460/380-415	60/50	YES	1.15/1.00	3	#8 w/GND	276 619 60	YES
		3P	460/380-415	60/50	YES	1.15/1.00	6-90°	#8 w/GND	276 719 60	YES
		3P	575	60	YES	1.15	3	#8 w/GND	276 629 60	YES
	316 SS	3P	380	60	YES	1.15	3	#8 w/GND	276 669 40	
		3P	380	60	YES	1.15	6-90°	#8 w/GND	276 789 40	
		3P	415	50	YES	1.00	3	#8 w/GND	276 699 40	
		3P	460/380-415	60/50	YES	1.15/1.00	3	#8 w/GND	276 619 40	YES
		3P	460/380-415	60/50	YES	1.15/1.00	6-90°	#8 w/GND	276 719 40	
		3P	575	60	YES	1.15	3	#8 w/GND	276 629 40	

NOTES:

1. Models designated above as Sand Fighter™ are water well construction.
2. All 316 SS and Ni-Resist models are equipped with Sand Fighter sealing system.
3. All models listed above include factory-installed leads (13 ft).